



UT232A

Preliminary

CMOS

HIGH PERFORMANCE RS-232 LINE DRIVERS/RECEIVERS

DESCRIPTION

The UTC **UT232A** is a high performance RS-232 line drivers/receivers. It meets RS-232D and V.28 specifications.

Its high performance includes increased drive current for longer and more flexible cable configurations and 10V/μs slew rate, 120kbps guaranteed transmission rate. For easiler use , enhancements include better ESD protection, low power dissipation and four external small 0.1μF charge pump capacitors.

The UTC **UT232A** is available in DIP-16 package and SOP-16 package.

FEATURES

- * Single power supply: 5V
- * Low power supply current: 10mA
- * Multiple drivers and receivers
- * Receiver input levels:±30V
- * 3-State outputs of TTL/CMOS receiver
- * High output slew rate: 10V/μs under load
- * High data rate: 120kbps under load
- * Four external small charge pump capacitors: 0.1μF

ORDERING INFORMATION

| Ordering Number | | Package | Packing |
|-----------------|---------------|---------|-----------|
| Lead Free | Halogen Free | | |
| UT232AL-D16-T | UT232AG-D16-T | DIP-16 | Tube |
| UT232AL-S16-R | UT232AG-S16-R | SOP-16 | Tape Reel |

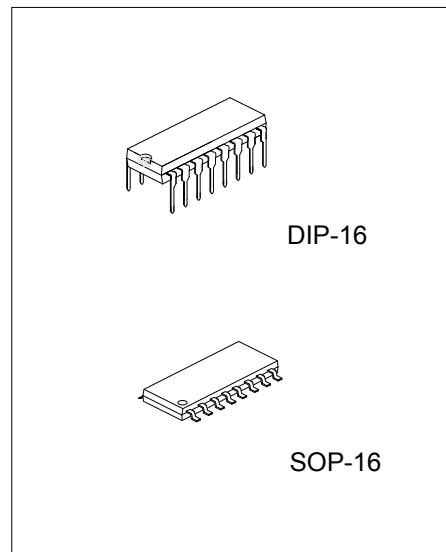

Lead-free: UT232AL
Halogen-free: UT232AG

| | |
|---|---|
| <p>UT232AL-D16-T</p> <p>(1) Packing Type (2) Package Type (3) Lead Free</p> | <p>(1) R: Tape Reel, T: Tube (2) D16: DIP-16, S16: SOP-16 (3) G: Halogen Free, L: Lead Free</p> |
|---|---|

■ PIN CONFIGURATION

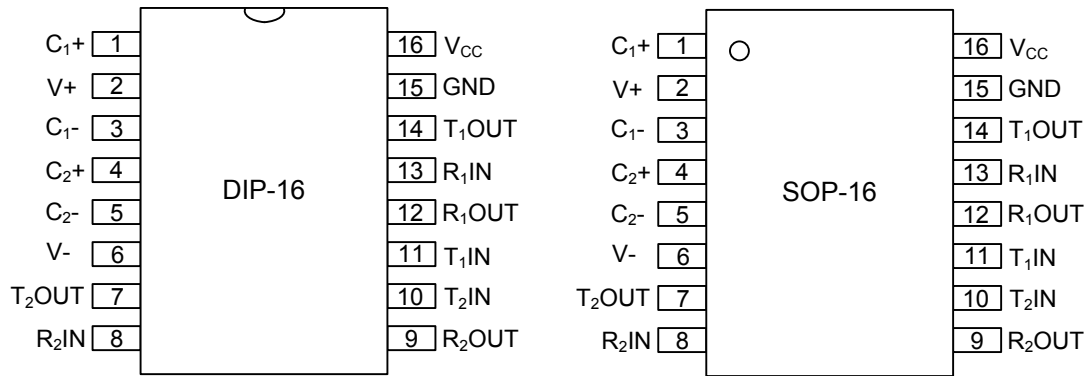

■ PIN DESCRIPTION

| PIN NO. | PIN NAME | DESCRIPTION |
|---------|--------------------|--|
| 1 | C ₁₊ | Positive terminal of the voltage doubler Charge-Pump Capacitor |
| 2 | V+ | Positive voltage generated by the charge pump |
| 3 | C ₁₋ | Negative terminal of the voltage doubler Charge-Pump Capacitor |
| 4 | C ₂₊ | Positive terminal of inverting Charge-Pump Capacitor |
| 5 | C ₂₋ | Negative terminal of inverting Charge-Pump Capacitor |
| 6 | v- | Negative voltage generated by the charge pump |
| 7 | T ₂ OUT | RS-232 Transmitter Outputs |
| 8 | R ₂ IN | RS-232 Receiver Inputs |
| 9 | R ₂ OUT | TTL/CMOS Receiver Outputs |
| 10 | T ₂ IN | TTL/CMOS Transmitter Inputs |
| 11 | T ₁ IN | TTL/CMOS Transmitter Inputs |
| 12 | R ₁ OUT | TTL/CMOS Receiver Outputs |
| 13 | R ₁ IN | RS-232 Receiver Inputs |
| 14 | T ₁ OUT | RS-232 Transmitter Outputs |
| 15 | GND | Ground |
| 16 | V _{CC} | Power Supply |

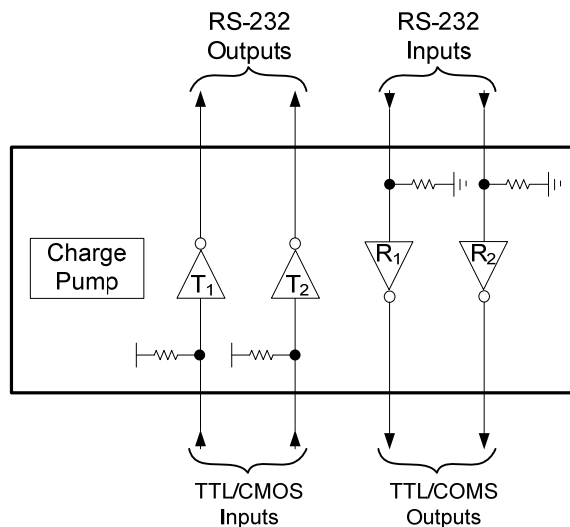

■ ABSOLUTE MAXIMUM RATINGS

| PARAMETER | SYMBOL | RATINGS | UNIT |
|--------------------------------------|-----------|--------------------------------|-------------|
| Supply voltage range | V_{CC} | 6 | V |
| Positive-output supply voltage range | V^+ | $(V_{CC}-0.3) \sim +13.2$ | V |
| Negative-output supply voltage range | V^- | 13.2V | V |
| Input Voltages | T_{IN} | $-0.3 \sim (V_{CC}+0.3)$ | V |
| | R_{IN} | ± 30 | V |
| Output Voltages | T_{OUT} | $(V^+, +0.3) \sim (V^-, -0.3)$ | V |
| | R_{OUT} | $-0.3 \sim (V_{CC}+0.3)$ | V |
| Short Circuit Duration | T_{OUT} | Continuous | |
| Power Dissipation | P_D | 375 | mW |
| Operating Temperature | T_{OPR} | $0 \sim +70$ | $^{\circ}C$ |

Note : Absolute maximum ratings are those values beyond which the device could be permanently damaged.

Absolute maximum ratings are stress ratings only and functional device operation is not implied.

■ ELECTRICAL CHARACTERISTICS

($V_{CC} = +5V \pm 10\%$; 0.1 μ F charge pump capacitors; T_{MIN} to T_{MAX} unless otherwise specified.)

| PARAMETER | SYMBOL | TEST CONDITIONS | MIN | TYP | MAX | UNIT | |
|---------------------------------|--------|-----------------|---|---------|----------|------|------------|
| TTL INPUT | | | | | | | |
| Logic Threshold | Low | V_{TL} | $T_{IN}; \overline{EN}, \overline{SD}$ | | | 0.8 | V |
| | High | V_{TH} | $T_{IN}; \overline{EN}, \overline{SD}$ | 2.0 | | | V |
| Logic Pull up Current | | I_{TH} | $T_{IN}=0V$ | | 15 | 200 | μ A |
| Maximum Data Rate | | | $C_L=2500pF, R_L=3k\Omega$ | 120 | | | kps |
| TTL OUTPUT | | | | | | | |
| TTL/CMOS Output Voltage | Low | V_{OL} | $I_{OUT}=3.2mA; V_{CC}=+5V$ | | | 0.4 | V |
| | High | V_{OH} | $I_{OUT}=-1.0mA$ | 3.5 | | | V |
| RS-232 OUTPUT | | | | | | | |
| Output Voltage Swing | | $V_{O(SW)}$ | All transmitter outputs loaded With 3k Ω to Ground | ± 5 | ± 9 | | V |
| Output Resistance | | R_O | $V_{CC}=0V; V_{OUT}=\pm 2V$ | 300 | | | Ω |
| Output Short Circuit Current | | $I_{O(SC)}$ | Infinite duration | | ± 18 | | mA |
| RS-232 INPUT | | | | | | | |
| Voltage Range | | $V_{I(SW)}$ | | -30 | | +30 | V |
| Voltage Threshold | Low | $V_{THR(L)}$ | $V_{CC}=5V, T_A=+25^{\circ}C$ | 0.8 | 1.2 | | V |
| | High | $V_{THR(H)}$ | | | 1.7 | 2.4 | V |
| Hysteresis | | V_{HYS} | $V_{CC}=5V, T_A=+25^{\circ}C$ | 0.2 | 0.5 | 1.0 | V |
| Resistance | | R_I | $T_A=+25^{\circ}C, -15V \leq V_{IN} \leq +15V$ | 3 | 5 | 8 | k Ω |
| DYNAMIC CHARACTERISTICS | | | | | | | |
| Propagation Delay, RS232 to TTL | | t_{PD} | | | 1.5 | | μ s |
| Instantaneous Slew Rate | | SR | $C_L=10pF, R_L=3-7k\Omega;$ $T_A=+25^{\circ}C$ | | | 30 | V/ μ s |
| Transition Region Slew Rate | | SR | $C_L=2500pF, R_L=3k\Omega;$ measured from $+3V \sim -3V$ or $-3V \sim +3V$ | | 10 | | V/ μ s |
| POWER REQUIREMENTS | | | | | | | |
| V_{CC} Power Supply Current | | I_{CC} | No load, $T_A=+25^{\circ}C; V_{CC}=5V$ | | 10 | 15 | mA |
| | | | All transmitters $R_L=3k\Omega; T_A=+25^{\circ}C$ | | 25 | | mA |

■ FUNCTION DESCRIPTION

Driver/Transmitter

The drivers are inverting transmitters, which accept TTL or CMOS inputs and output the RS-232 signals with an inverted sense relative to the input logic levels. Typically the RS-232 output voltage swing is $\pm 9V$. Even under worst case loading conditions of $3k\Omega$ and $2500pF$, the output is guaranteed to be $\pm 5V$, which is consistent with the RS-232 standard specifications. The transmitter outputs are protected against infinite short-circuits to ground without degradation in reliability.

The instantaneous slew rate of the transmitter output is internally limited to a maximum of $30V/\mu s$. However, the transition region slew rate of these enhanced products is typically $10V/\mu s$. The smooth transition of the loaded output from VOL to VOH clearly meets the monotonicity requirements.

Receivers

The receivers convert RS-232 input signals to inverted TTL signals. Since the input is usually from a transmission line, where long cable lengths and system interference can degrade the signal, the inputs have a typical hysteresis margin of $0.5V$.

This ensures that the receiver is virtually immune to noisy transmission lines. The input thresholds are $0.8V$ minimum and $2.4V$ maximum, again well within the $\pm 3V$ RS-232 requirements. The receiver inputs are also protected against voltages up to $\pm 30V$. Should an input be left unconnected, a $5k\Omega$ pull down resistor to ground will commit the output of the receiver to a high state.

In actual system applications, it is quite possible for signals to be applied to the receiver inputs before power is applied to the receiver circuitry.

This occurs, for example, when a PC user attempts to print, only to realize the printer wasn't turned on. In this case an RS-232 signal from the PC will appear on the receiver input at the printer. When the printer power is turned on, the receiver will operate normally. All of these enhanced devices are fully protected.

Charge Pump

The charge pump section of these devices allows the circuit to operate from a single $+5V \pm 10\%$ power supply by generating the required operating voltages internal to the devices. The charge pump consists of a voltage doubler and a voltage inverter. As shown in Figure 1, an internal oscillator triggers the charge accumulation and voltage inversion. The voltage doubler momentarily stores a charge on capacitor C1 equal to V_{CC} , referenced to ground. During the next transition of the oscillator this charge is boot-strapped to transfer charge to capacitor C3. The voltage across C3 is now from V_{CC} to $V+$.

In the inverter section as shown in Figure 2, the voltage across C3 is transferred to C2 forcing a range of $0V$ to $V+$ across C2. Boot-strapping of C2 will then transfer charge to C4 to generate $V-$. One of the significant enhancements over previous products of this type is that the values of the capacitors are no longer critical and have been decreased in size considerably to $0.1\mu F$. Because the charge pump runs at a much higher frequency, the $0.1\mu F$ capacitors are sufficient to transfer and sustain charges to the two transmitters.

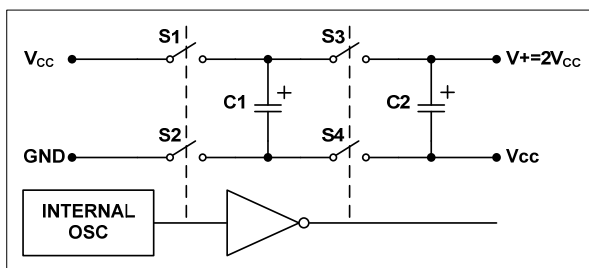

Figure 1 Charge Pump Voltage Doubler

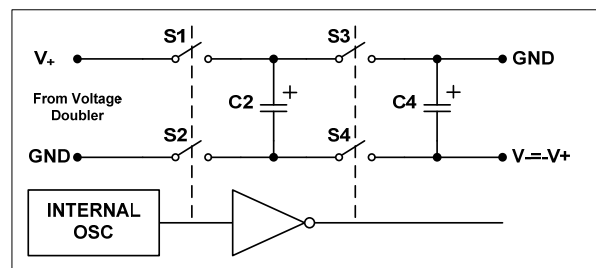

Figure 2 Charge Pump Voltage Inverter

■ APPLICATION INFORMATION

To operate from a single +5V supply, the UTC **UT232A** include charge pump voltage converters which can allow it. To generate the RS-232 output levels these converters convert the +5V input power to the ±10V needed. The current drain due to charge pump operation is considerably reduced, typically to 400µA with this power supplied externally. The UTC **UT232A** can operate over the commercial, industrial and military temperature ranges.

Protection from Shorts to ±15V

Against shorts to ground, any other driver output, and V^+ or V^- the driver outputs are protected. If the outputs is connected to voltages higher than ±15V inadvertently, then the external protection is recommended to be provided. While voltages exceeding ±15V ,for protection, two back-to-back zener diodes which is connected from each output to ground will clamp the outputs to an acceptable voltage level.

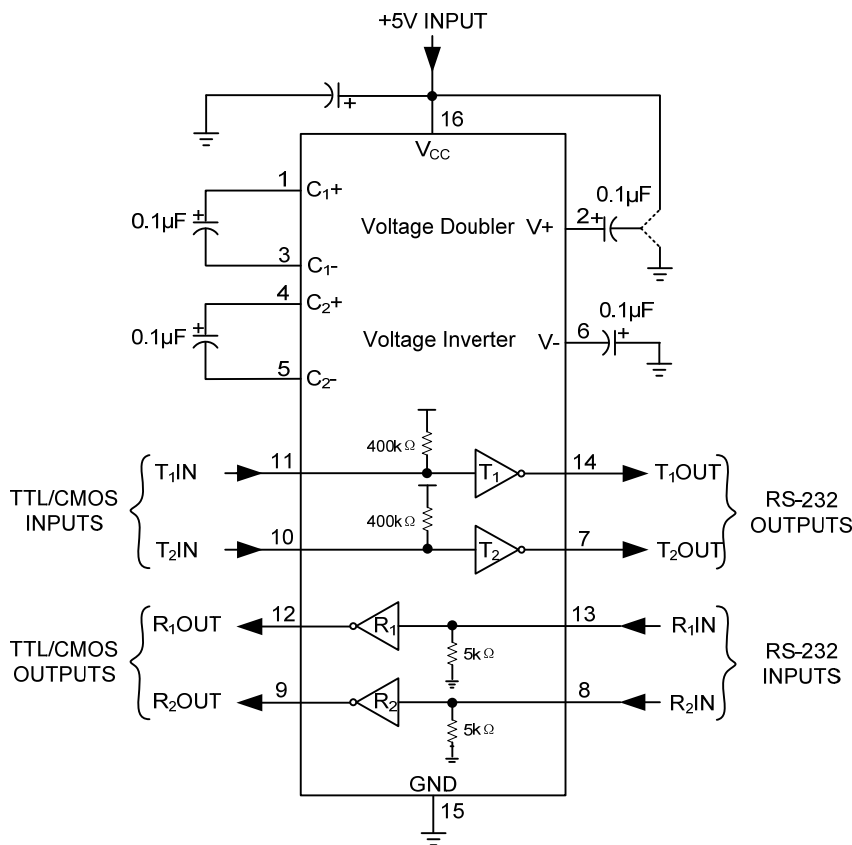

Connecting the capacitor to V_{CC} (+5V) is recommended. The negative terminal of the V+ storage capacitor can be connected to either V_{CC}.

UTC assumes no responsibility for equipment failures that result from using products at values that exceed, even momentarily, rated values (such as maximum ratings, operating condition ranges, or other parameters) listed in products specifications of any and all UTC products described or contained herein. UTC products are not designed for use in life support appliances, devices or systems where malfunction of these products can be reasonably expected to result in personal injury. Reproduction in whole or in part is prohibited without the prior written consent of the copyright owner. The information presented in this document does not form part of any quotation or contract, is believed to be accurate and reliable and may be changed without notice.